

## AIR PREPARATION UNITS

REGULATOR Series R1N  
( with built in Non Return Valve )

Cat No R1N - 01 - 01

### AIR REGULATOR ( with built in Non Return Valve ) - 1/4 3/8 1/2

#### Features

- Conforms to ISO 6953 - 1
- Suitable for panel and modular mountings
- Non raising ' Press to Lock ' adjusting knob for locking at any set pressure
- Diaphragm operated, relieving type
- Pressure compensated by Balanced poppet.
- Flow compensated in models R14 and R15 ( with venturi ) for faster response
- Good flow and regulating characteristics.
- Built in non return valve allows free air flow in reverse direction. When the inlet air is reduced by and below the setup pressure.



#### Application

Apart from its basic regulating characteristics in forward direction, this regulator with a built in non return valve allows free air flow in reverse direction, thus enabling to be used in applications requiring cylinders to exert two different force during extending and retracting strokes.

#### Technical Specification

Model	R13...N	R14...N	R15...N
Medium	Compressed air - Filtered		
Port size	G1/4	G3/8	G1/2
Pressure gauge port size	G1/8	G1/8	G1/8
Flow rate (lts / min) <sup>@</sup>	600	2500	4000
Maximum supply pressure (bar)	15		
Regulating pressure range <sup>#</sup> (bar)	0.2 - 2, 0.2 - 4, 0.5 - 7, 0.5 - 10 (Standard)		
Ambient / Medium temperature	5° - 60° C		
Installation	Any position		
Materials of construction	Aluminium, Brass, Steel, Acetal, SS, Nitrile		
Optional accessories <sup>*</sup>	Clamp, Modular mounting kit, Pressure gauge		
Weight (Kg)	0.15	0.40	0.90

<sup>@</sup> Supply pressure 7 bar , Set pressure 6 bar , Pressure drop  $\Delta p = 1\text{bar}$  ( For standard models )

<sup>#</sup> For details see " How to order "

<sup>\*</sup> For details refer optional accessories Cat No APA - 01 - C

#### Precautions

1. Note the direction of flow before installation and connect piping accordingly.
2. Flush pipings for dirt, dust, rust and other foreign particles.
3. Install in clean atmosphere.
4. Nipples of taper threads ( R ) to be used with teflon tape. Ensure teflon tape does not enter the unit during tightening. Nipples of straight threads ( G ) to be used with sealing washer.

#### Pressure Setting

Pull the knob and adjust by turning the knob clockwise to increase the pressure. Push the knob back to its locked position. ( Turning the knob counter clockwise will reduce the pressure )

# AIR PREPARATION UNITS

## REGULATOR Series R1N ( with built in Non Return Valve )

Cat No R1N - 01 - 01

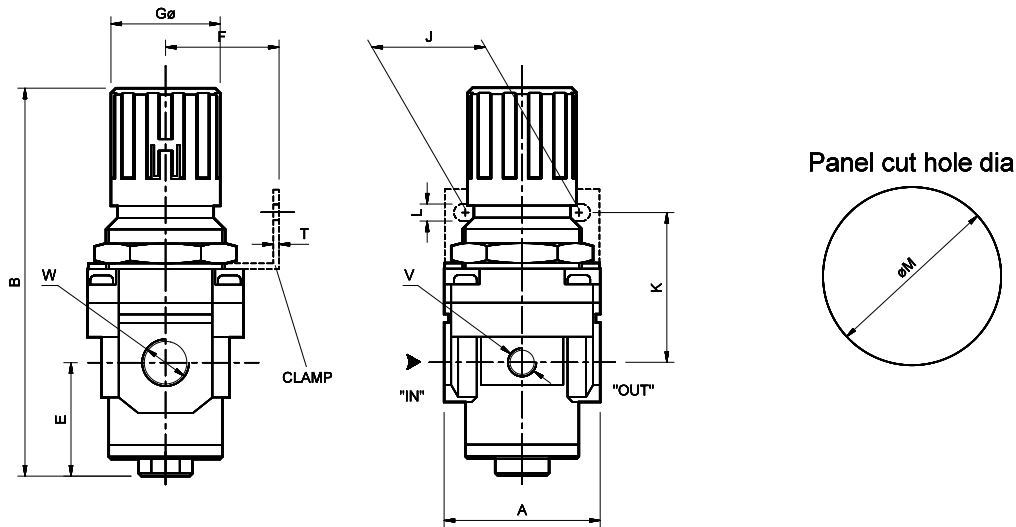

Model	W	V	A	B	E	F	GØ	J	K	L	T	ØM
R13...N	G1/4	G1/8	SQ 40	81	13	30	28	28	45	5.5	2	31
R14...N	G3/8	G1/8	SQ 55	135	40	40	40	40	53	6.5	2	43
R15...N	G1/2	G1/8	SQ 70	165	40	50	51	55	62	8.5	2	53

For Details of Clamp see optional accessories Cat No APA - 01 - C

### Flow Graphs

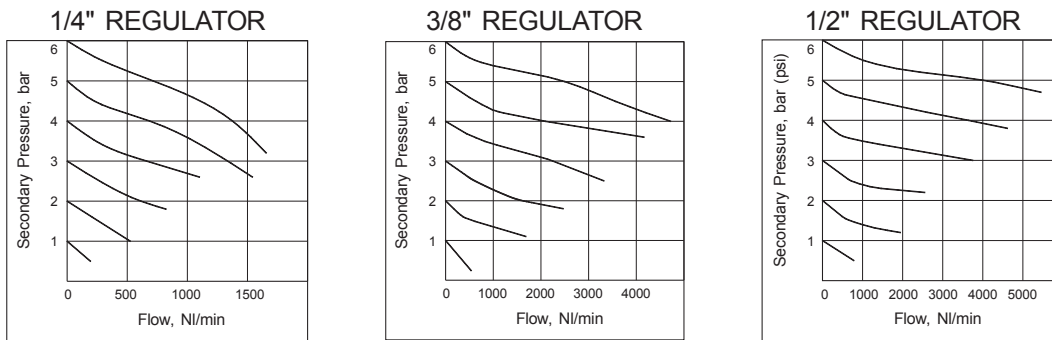

### How to order

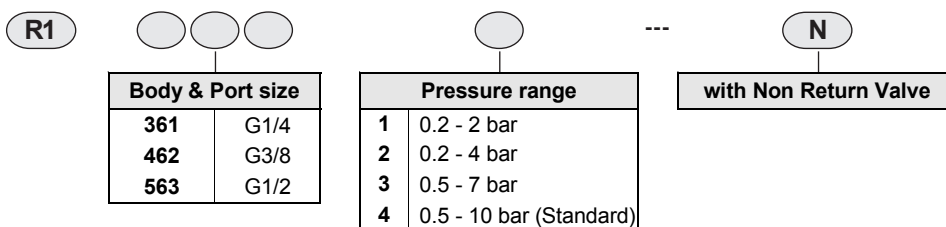

**Ordering Example** :- Regulator - 3/8 size ( with G3/8 port ), with pressure range 0.5 - 7 bar with Non Return Valve  
Ordering No : R14623-N.

If ordered as 3/8 Regulator, our standard model R14624, G3/8 with pressure range 0.5 - 10 bar will be supplied.