

MULTI POSITION CYLINDER

Series A63, A64

Cat No A63, A64 - 01 - 03 - A

Multi Position Cylinders - (Series A63, A64 - Ø32 to 100 mm)

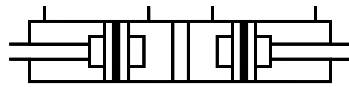

A63 - Magnetic

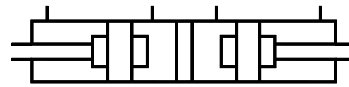

A64 - Non-magnetic



Features

- Elastomer end cushioning
- Wide varieties of mountings
- Space saving
- Magnetic and Non magnetic version
- Aluminium profile (square) cylinder barrel
- Magnetic sensor common for all sizes
(Refer Magnetic sensor catalogue)

Technical Specifications

Cylinder bore Ø (mm)	32	40	50	63	80	100
Standard strokes * (mm)	10, 15, 20, 25, 30, 40, 50, 60, 70, 80					
Medium	Compressed air - filtered - lubricated					
Working pressure range	0.5 - 10 bar					
Medium temperature	5° - 60° c					
Materials of construction	Aluminium, Nitrile, Steel, Polyurethane					
Mountings @	Basic cylinder, Foot mounting, Front flange, Rear flange, Male clevis, Female clevis,					
Accessories #	Clevis foot bracket, Wall mounting bracket, Rod end fork, Rod end aligner, Rod end spherical eye					

* For Non standard or longer stroke cylinders, contact your regional office, dealer or **JANATICS**

Note : For details of Cylinder Accessories, refer catalogue **Cat No A63, A64 - 01 - 02 - C** (Page no. 1.5.1) and Magnetic sensor, refer catalogue **Series AM4** (Page no. 1a.2.1)

Multi position cylinder can transform to 3 or 4 positions depending upon selection of their strokes, by connecting two cylinders of identical piston diameter and different stroke length in series (back-to-back). The pistons of this cylinder travels in opposite directions. The cylinders is precisely stopped at the end of each stroke by mechanical stopper. One end of the piston rod should be fixed for the cylinder to execute motion. The cylinder must be connected only with slideing objects i.e. linear guides. The cylinder transforms to the end position directly, or through intermediate position, which can be obtained through appropriate actuation.

Two cylinders of identical diameter with different stroke length connected in series to achieve 4 positions:

The multiposition cylinder used in this system executes to 4 positions including home position. The cylinder are with identical diameter Ø32 with strokes of cylinders being 50 mm and 100 mm i.e. 1:2 ratio. The required sequence of the cylinder were be obtained by energising the valves in appropriate order as mentioned below:

- Ports A, D - Stroke 1
- Ports B, D - Stroke 2
- Ports A, C - Stroke 3
- Ports B, C - Stroke 4

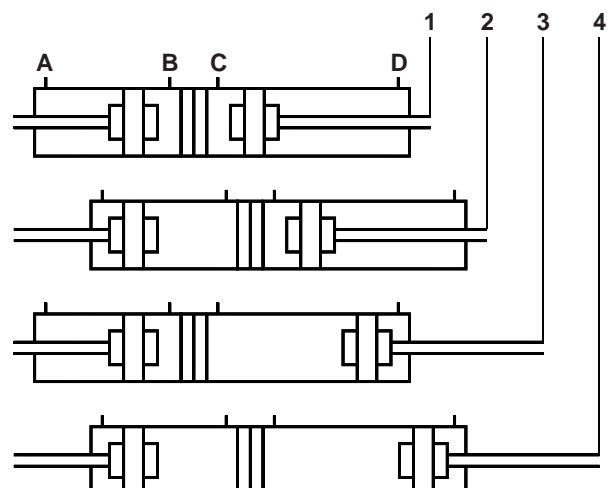

MULTI POSITION CYLINDER

Series A63, A64

Cat No A63, A64 - 01 - 03 - A

Multi Position Cylinder - (Series A63, A64 - Ø32 to 100 mm)

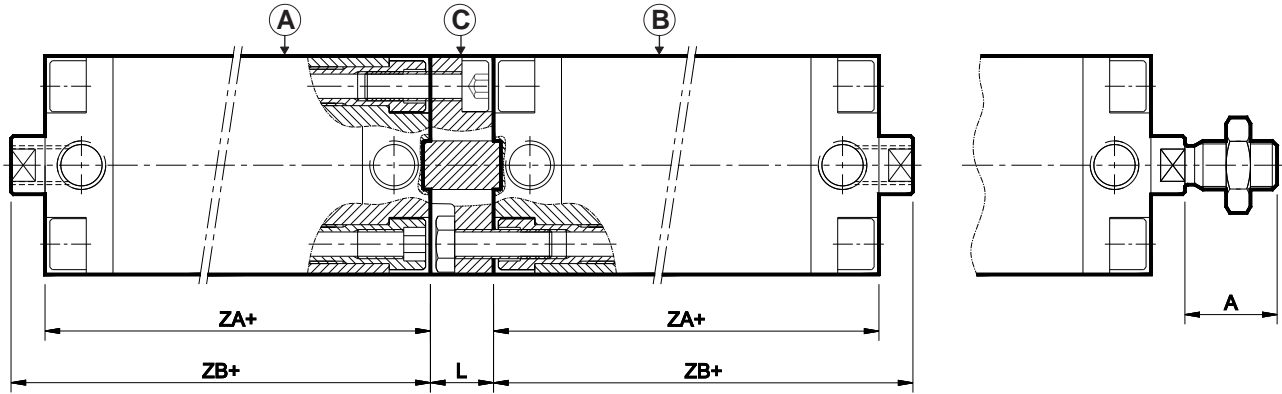

+ Add stroke

Cylinder bore Ø	ZA	Tol	ZB	Tol	L	A ^{-0.5}
32	44	±0.5	51	±1.6	13	19
40	45	±0.7	52		15	19
50	45		53		15	22
63	49	±0.8	57	±2	15	22
80	54		64		17	28
100	67	±1	77		19.5	28

Intermediate Flange - (Ø32 - 100 mm)

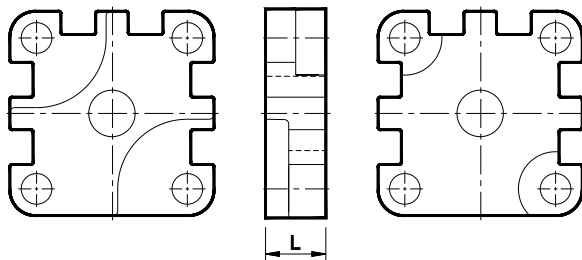

Cylinder bore Ø	L	Ordering No.
32	13	AJ2032
40	15	AJ2040
50		AJ2050
63		AJ2063
80	17	AJ2080
100	19.5	AJ2100

Note :- Supplied with hexagonal bolt - 2 nos., Socket head cap screw - 2nos. & Guide pin - 1 no.

How to order

Female Thread

Ordering example :- a. A63050050O, b. A63050060O, c. Intermediate flange = Ordering no. A63050050060MO

Male Thread

Ordering example :- a. A63050050O-M, b. A63050060O-M, c. Intermediate flange = Ordering no. A63050050060MOM

For details of Mountings & Accessories refer Product Catalogue Cat No A63, A64 - 01 - 02 - C (Page no. 1.5.1)

Subject to change