

AIR CYLINDER

Series A16, A17

Cat No A16, A17 - 01 - 01 - B

AIR CYLINDERS Double Acting (Ø125, 160, 200) mm

As per ISO 15552 / VDMA 24562 standards

Features

- Adjustable cushioning at both ends
- Wide varieties of mountings
- Low friction
- Long life
- High temperature (Viton seals) 150°C max.
- Non corrosive Stainless steel piston rod and piston rod lock nut (SS 304)

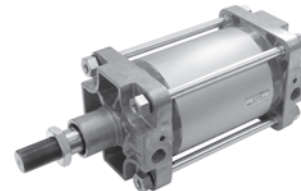

Technical Specifications

Cylinder bore Ø (mm)		125	160	200
Cushion stroke (mm)		40	40	40
Standard strokes * (mm)		50 80 100 125 160 200 250 300 320 400 500		
Medium		Compressed air - filtered - lubricated		
Working pressure		0.5 - 10 bar		
Medium temperature	Regular	5° - 60° C		
	High temperature applications**	5° - 150° C max.		
Materials of construction		Aluminium, Brass, Nitrile, Steel, Acetal, Iron, polyurethane		
Mountings		Basic cylinder, Foot mounting, Front flange, Rear flange, Male clevis, Female clevis, Female clevis (King pin), Centre trunnion, Front trunnion, Rear trunnion		
Accessories		Clevis foot bracket, Wall mounting bracket, Trunnion bracket, Rod end fork, Rod end aligner, Rod end spherical eye		

* For Non standard or longer stroke cylinders, contact your regional dealer or **JANATICS**

** Refer Special Ordering number.

Output force (force in N : 1N = 0.1 kgf)

Cylinder bore Ø (in mm)	Rod Ø (in mm)		Working pressure in bar								
			2	3	4	5	6	7	8	9	10
Ø125	32	Extend	2209	3313	4417	5522	6626	7731	8835	9940	11044
		Retract	2064	3096	4128	5160	6192	7224	8256	9288	10320
Ø160	40	Extend	3619	5428	7238	9047	10857	12666	14476	16286	18095
		Retract	3392	5089	6785	8482	10178	11875	13571	15268	16964
Ø200	40	Extend	5654	8482	11309	14137	16964	19792	22619	25446	28274
		Retract	5428	8143	10857	13571	16286	19000	21714	24429	27143

(Above values have been worked out taking frictional loss into consideration)

AIR CYLINDER

Series A16, A17

Cat No A16, A17 - 01 - 01 - B

Basic cylinder

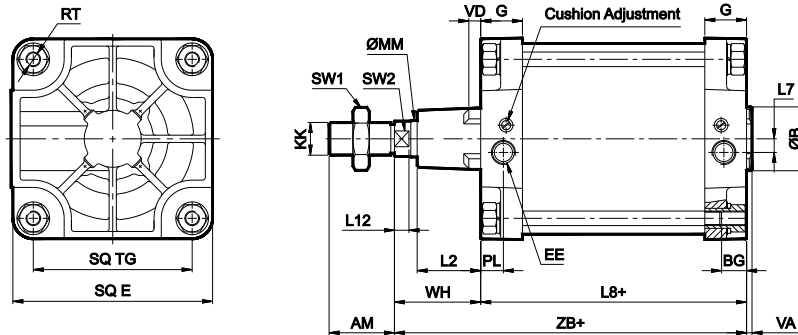

+ Add stroke

Cylinder bore Ø	KK	AM	MM	SW2	L12	SW1	B e11	VD	VA	L2	E max	G	TG	RT	BG min	EE	PL	L7	WH ± 2.2	ZB	L8	Stroke tol
125	M27 x 2	54	32	27	13	41	60	6	6	50.5	142	44	110	M12	20	G1/2	20	12	65	225 ± 1.2	160 ± 1.0	+4 0
160	M36 x 2	72	40	36	16	55	65	8	6	60	182	51	140	M16	24	G3/4	26	15	80	260 ± 1.5	180 ± 1.1	
200	M36 x 2	72	40	36	16	55	75	8	6	70	222	46	175	M16	24	G3/4	25	15	95	275 ± 1.5	180 ± 1.6	

MOUNTINGS FOR AIR CYLINDER Series A16, A17

Foot mounting

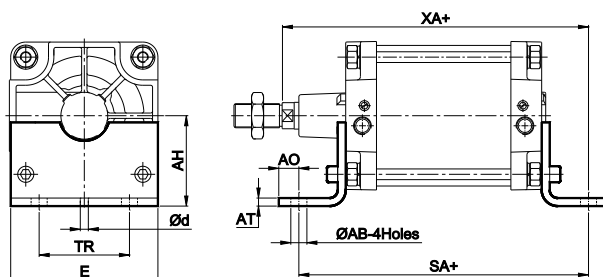

+ Add stroke

Cylinder bore Ø	TR ± 0.3	AB H14	AH Js16	AO max	AT	E	SA ± 2	d*	XA ± 2	Ordering no.
125	90	16.5	90	17	8	142	250	11.8	270	ML0125
160	115	18.5	115	17	10	182	300	11.8	320	ML0160
200	135	24	135	30	12	222	320	11.8	345	ML0200

* Suitable for reaming

Front flange

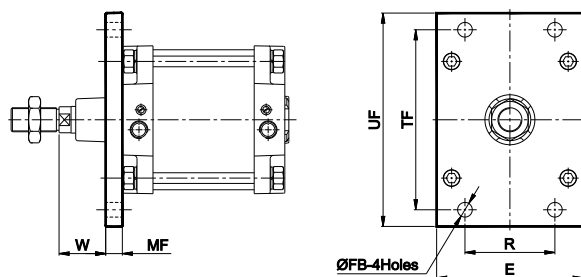

+ Add stroke

Cylinder bore Ø	TF ± 0.3	R ± 0.3	FB H13	MF	UF	E	W ± 2.5	Ordering no.
125	180	90	16	20	211	142	45	MF0125
160	230	115	18	20	276	182	60	MF0160
200	270	135	22	25	320	222	70	MF0200

Rear flange

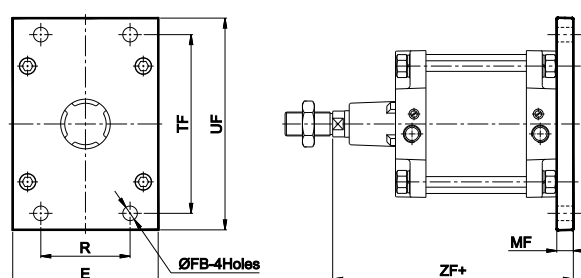

+ Add stroke

Cylinder bore Ø	TF ± 0.3	R ± 0.3	FB H13	MF	UF	E	ZF ± 2	Ordering no.
125	180	90	16	20	211	142	245	MF0125
160	230	115	18	20	276	182	280	MF0160
200	270	135	22	25	320	222	300	MF0200

AIR CYLINDER

Series A16, A17

Cat No A16, A17 - 01 - 01 - B

Male clevis

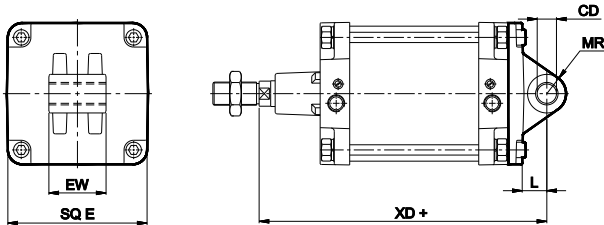

+ Add stroke

Cylinder bore Ø	CD H9	EW	Tol	L min	MR max	E max	XD ± 2	Ordering no.
125	25	70	- 0.5 - 1.2	30	26	142	275	MS0125
160	30	90		35	31	182	315	MS0160
200	30	90		35	31	222	335	MS0200

Female clevis

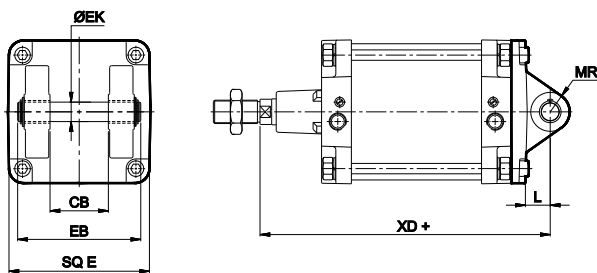

+ Add stroke

Cylinder bore Ø	EK e8	L min	MR max	EB max	CB H14	E max	XD ± 2	Ordering no.
125	25	30	26	148	70	142	275	MD0125
160	30	35	31	191	90	182	315	MD0160
200	30	35	31	191	90	222	335	MD0200

Female clevis (King pin)

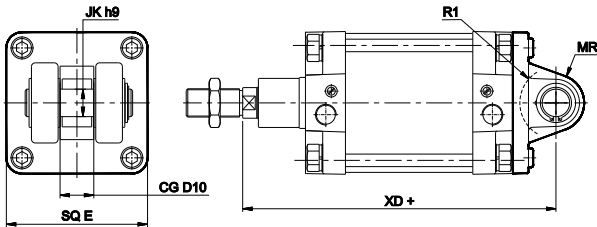

+ Add stroke

Cylinder bore Ø	JK h9	CG D10	R1	MR max	SQ E	XD	Tol	Ordering no.
125	30	37	42	30	142	275	± 2	MK0125
160	35	43	46	36	182	315		MK0160

Front trunnion

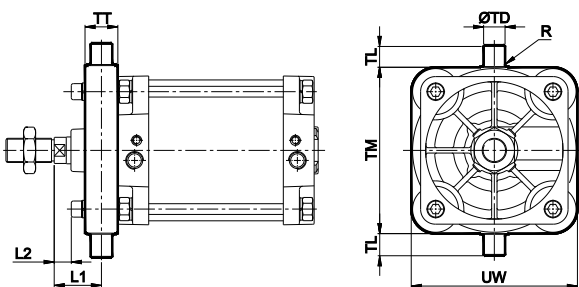

+ Add stroke

Cylinder bore Ø	TD e9	TL h14	TM h14	UW	TT	R	L1 ± 2.5	L2 Approx.	Ordering no.
125	25	25	160	155	44	2	43	6.5	MT0125
160	32	32	200	195	49	2.5	55.5	11.5	MT0160
200	32	32	250	248	49	2.5	70.5	26.5	MT0200

Rear trunnion

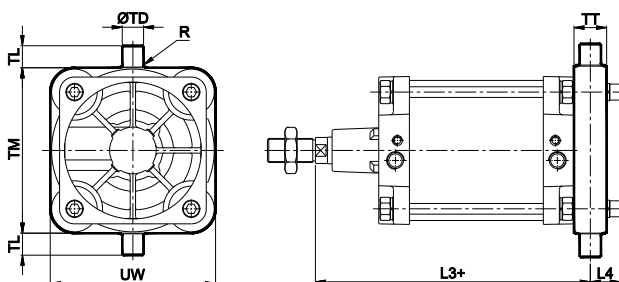

+ Add stroke

Cylinder bore Ø	TD e9	TL h14	TM h14	UW	TT	R	L3 ± 1.8	L4	Ordering no.
125	25	25	160	155	44	2	247	36.5	MT0125
160	32	32	200	195	49	2.5	284.5	44	MT0160
200	32	32	250	248	49	2.5	299.5	44	MT0200

AIR CYLINDER

Series A16, A17

Cat No A16, A17 - 01 - 01 - B

Centre trunnion

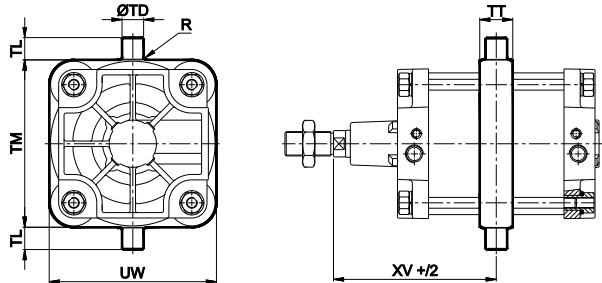

+ Add stroke

Cylinder bore Ø	TD e9	TL h14	TM h14	UW	TT	R	XV ±2.5
125	25	25	160	155	44	2	145
160	32	32	200	195	49	2.5	170
200	32	32	250	248	49	2.5	185

Note : Cylinder with centre trunnion is factory fitted, please contact JANATICS - H.O

Accessories for Air Cylinder series A16, A17

Clevis foot bracket

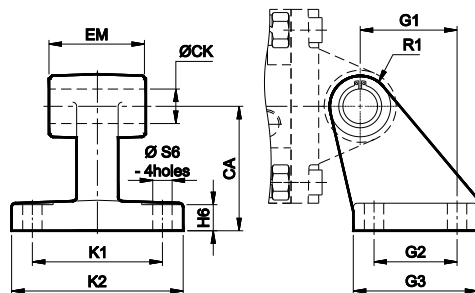

Cylinder bore Ø	K1 Js14	G2 Js14	S6 H13	CA Js15	CK H9	EM	Tol	G1 Js14	Tol	H6	R1 max	K2	G3	Ordering no. @
125	94	60	14	90	25	70	-0.5 -1.5	70	±0.2	20	23.5	124	90	AA0125
160	118	88	14	115	30	90		97		25	31.5	156	126	AA0160
200	122	90	18	135	30	90		105	±0.3	30	31.5	162	130	AA0200

@ Adoptable to cylinder with female clevis

Clevis foot bracket (with spherical bearing)

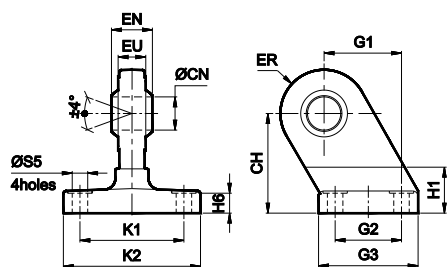

Cylinder bore Ø	K1 Js14	G2 Js14	S5 H13	CH Js15	CN H7	EU max	G1 Js14	H6	ER max	K2	G3	EN -0.1	L5	H1 max	Ordering no. @
125	94	60	14	90	30	25	70	20	40	124	90	37	2	50	AB1125

@ Adoptable to cylinder with female clevis (King pin)

Wall mounting bracket

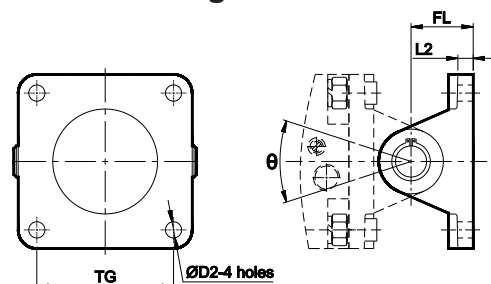

Cylinder bore Ø	TG	D2	L2	FL	θ°	Ordering no. @	Ordering no. #
125	110	13	10	50 ±0.2	80	AV0125	AW0125
160	140	17	10	55 ±0.2	80	AV0160	AW0160
200	175	17	11	60 ±0.2	90	AV0200	AW0200

@ Adoptable to cylinder with male clevis
Adoptable to cylinder with female clevis

AIR CYLINDER

Series A16, A17

Cat No A16, A17 - 01 - 01 - B

Trunnion bracket

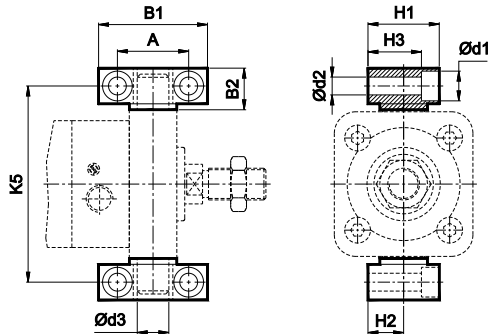

Cylinder bore Ø	B1	B2	A	d1	d2 H13	d3 H9	H1	H2	H3	K5 Js14	Ordering no.
125	75	28.5	50 ±0.2	20	14	25	50	25 ±0.1	37	192	AT100
160	92	40	60 ±0.3	25	18	32	60	30 ±0.2	43	245	AT0160
200	92	40	60 ±0.3	25	18	32	60	30 ±0.2	43	295	AT0160

Rod end Fork (ISO 8140)

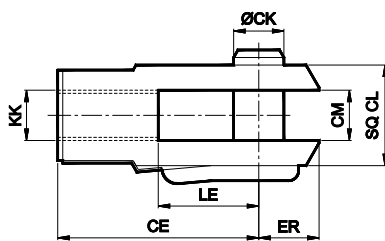

Cylinder bore Ø	KK	CE	CK f 8	CM B12	LE	ER max	CL	Ordering no.
125	M27 x 2	110	30	30	55	45	55	AF030
160 & 200	M36 x 2	144	35	35	72	53	70	AF035

Rod end Aligner

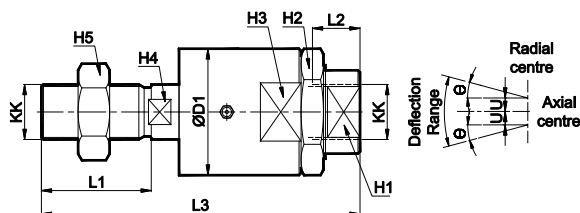

Cylinder bore Ø	KK	L1	L2	L3	H1	H2	H3	H4	H5	ØD1	U	θ°	Ordering no.
125	M27 x 2	54	42	157	41	55	55	24	41	62	1.5	5	AR027
160 & 200	M36 x 2	72	55	251	60	75	75	32	55	80	1.5	5	AR036

Rod end spherical eye (ISO 8139)

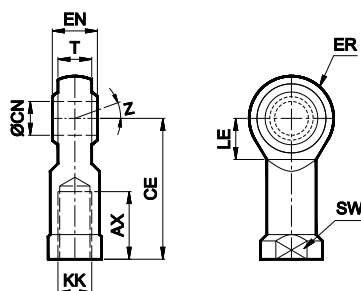

Cylinder bore Ø	KK	CN H9	T	EN h12	CE	LE min	ER max	AX	SW	Z	Ordering no.
125	M27 x 2	30	25	37	110	36	35	51	41	15°	AP027
160 & 200	M36 x 2	35	28	43	125	41	40	56	50		AP036

AIR CYLINDER

Series A16, A17

Cat No A16, A17 - 01 - 01 - B

ACCESSORIES FOR MAGNETIC CYLINDERS Series A17, A19

REED SWITCH

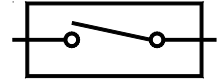

Function

The reed switch and clamping kit assembly is mounted on the Air cylinder (Series A17, A19), for proximity sensing. The piston of the cylinder is equipped with a permanent magnet which activates the reed switch on approaching it. The reed switch closes the circuit giving an electrical signal, which could be used further as required. The accuracy of the sensing distance depends on the speed of operation of the piston.

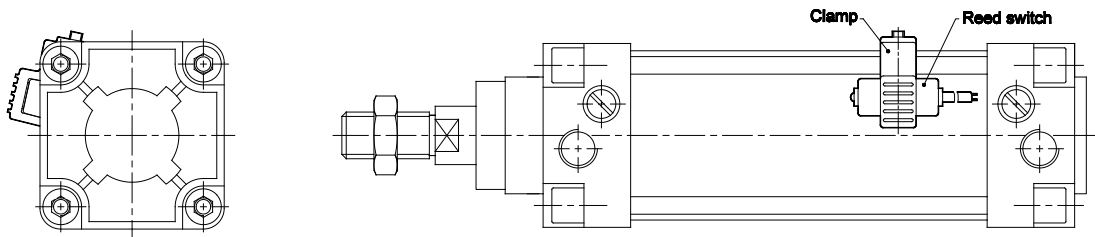

Technical Specifications - Reed Switch

Model	880006
Operating voltage	DC / AC 5 - 240V
Switching current	100mA max
Switch rating	10 W max
Voltage drop	3.5V max.
Response time	On + off <1ms
Switching logic	SPST, Normally open
Operating temperature	-10° to +70° C
Shock	30 G
Vibration	9 G
Protection circuit	None
Type of protection	IEC 529, IP67
Colour of LED	Green
Cable	Ø4, 2C, 2meter

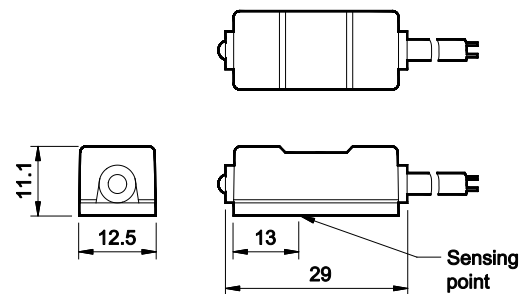

Cylinder bore Ø	X	Y	Ordering no. for Clamp (a)	Ordering no. Reed Switch (b)	Ordering no. (a+b)
125	71	76	SA0005	880006	AM1125
160	-	-	SA0006		AM1160
200	-	-	SA0007		AM1200

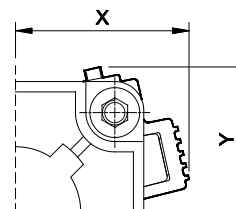

Circuit and connect diagram

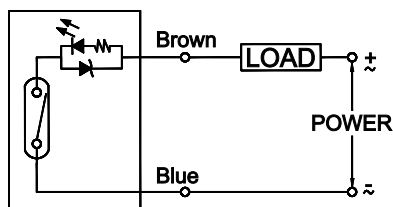

AIR CYLINDER

Series A16, A17

Cat No A16, A17 - 01 - 01 - B

How to order

A

Model		Piston Ø (mm)		Stroke (mm)		Mountings		Special Cylinders	
16	Standard cylinder	125	- Ø 125	050	- 50	O	- Basic	H	- High temp
17	Magnetic cylinder	160	- Ø 160	080	- 80	L	- Foot Mounting	S	- SS piston rod
		200	- Ø 200	100	- 100	F	- Front Flange		
				125	- 125	R	- Rear Flange		
				160	- 160	S	- Male Clevis		
				200	- 200	D	- Female Clevis		
				250	- 250	K	- Female Clevis (King pin)		
				300	- 300	N	- Front Trunnion		
				320	- 320	M	- Rear Trunnion		
				400	- 400	T	- Center Trunnion		
				500	- 500				

Example :

Ordering no. for standard cylinder with 160 dia bore, 100 mm stroke with female clevis mounting with High temp: **A16 160 100 D - T**







Note :

If ordered as 160 dia, 100 mm stroke cylinder, Basic cylinder **A16 160 100 O** will be supplied.

For repeat order when the details are taken from cylinder nameplate, mention the mounting style separately.

For ordering **Accessories** refer corresponding tables for ordering numbers.

For ordering individual **Mounting** kits (If needed separately) the order numbers are as below

Cylinder bore Ø	Foot mounting *	Front / Rear flange *	Male clevis *	Female clevis *	Front / Rear trunnion *	Female clevis (King pin) *
						
125	ML0125	MF0125	MS0125	MD0125	MT0125	MK0125
160	ML0160	MF0160	MS0160	MD0160	MT0160	MK0160
200	ML0200	MF0200	MS0200	MD0200	MT0200	---

* Supplied with 4nos. of screws

For your special requirements of cylinders or for further informations contact your regional dealer or **JANATICS**