

A10 - Magnetic

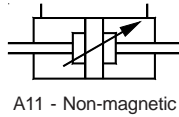

A11 - Non-magnetic

AIR CYLINDER

Series A10, A11

Cat No A10, A11 - 01 - 03

AIR CYLINDERS Double Acting (Ø32 - 100) mm

Features

- ❑ Adjustable cushioning at both ends
- ❑ Wide varieties of mountings
- ❑ Low friction
- ❑ Long life



Technical Specifications

Cylinder bore Ø (mm)	32	40	50	63	80	100
Cushion length (mm)	21	23	23	23	28	28
Standard strokes* (mm)	25 50 80 100 125 160 200 250 300 320 400 500					
Medium	Compressed air - filtered - lubricated					
Working pressure	0.5 - 10 bar					
Medium temperature	5° - 60° C					
Materials of construction	Aluminium, Brass, Nitrile, Polyurethane, Steel, Acetal					
Mountings	Basic cylinder, Foot mounting, Flange, Female clevis, Trunnion, Centre trunnion					
Accessories	Trunnion bracket, Rod end fork, Rod end aligner, Rod end spherical eye					

* For Non standard or longer stroke cylinders, contact your regional dealer or JANATICS

Output force (force in N : 1N = 0.1 kgf)

Cylinder bore Ø (in mm)	Rod Ø (in mm)	Working pressure in bar								
		2	3	4	5	6	7	8	9	10
32	12	124	187	249	311	373	435	498	559	621
40	16	190	285	380	475	570	665	760	855	950
50	20	297	445	594	742	891	1039	1187	1336	1484
63	20	505	757	1009	1261	1514	1766	2018	2270	2523
80	25	816	1225	1633	2041	2449	2857	3266	3674	4082
100	25	1325	1988	2650	3313	3976	4640	5300	5965	6625

(Above values have been worked out taking frictional loss into consideration)

Basic cylinder

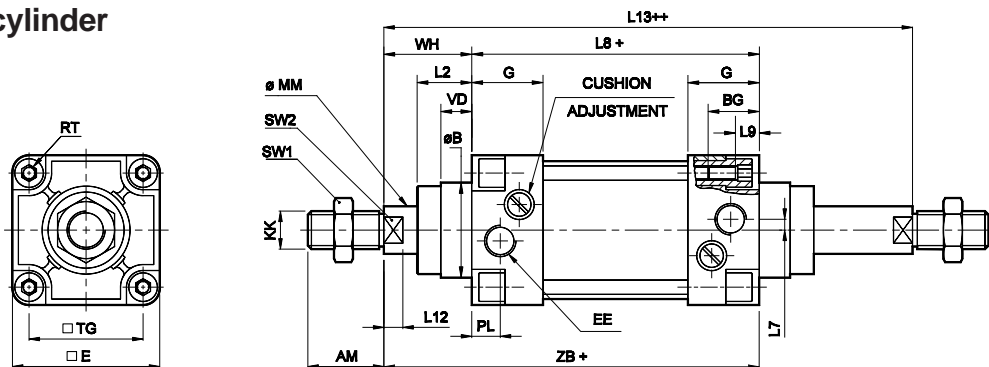

+ Add stroke
++ Add stroke twice

Cylinder bore Ø	KK	AM	MM	SW2	L12	SW1	B e11	VD	L2	E max	G	TG	RT	BG min	L9	EE	PL	L7	WH	Tol	ZB	Tol	L13	Tol	L8	Tol	Stroke Tol
32	M10 x 1.25	22	12	10	6	17	30	11	20.5	44	25	32	M6	16	5	G1/8	8.5	0	26		120		147		94	±0.6	+ 2 0
40	M12 x 1.25	24	16	13	6.5	19	35	12	24.5	55	28	40	M6	16	5	G1/4	12	3	30	±1.3	135	±0.9	166	±1.5	105		
50	M16 x 1.5	32	20	16	8	24	40	13	30	63	30	48	M6	16	5	G1/4	12	5	37		143		181		106	±0.7	
63	M16 x 1.5	32	20	16	8	24	45	14.5	30.5	83	33	60	M8	16	6	G3/8	16.5	10	37		158		196		121		+ 2.5 0
80	M20 x 1.5	40	25	21	10	30	45	18	38.5	98	33	72	M10	16	6	G3/8	16	15	46	±1.7	174	±1.1	221	±2	128	±0.8	
100	M20 x 1.5	40	25	21	10	30	55	20	44	115	37	89	M10	16	6	G1/2	18	15	51		189		241		138		

AIR CYLINDER

Series A10, A11

Cat No A10, A11 - 01 - 03

MOUNTINGS FOR AIR CYLINDER Series A10, A11

Foot mounting

+ Add stroke

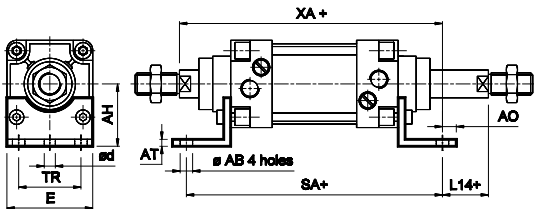

Cylinder bore Ø	TR ±0.3	AB	AH Js15	AO max	AT	E	d*	SA±Tol	L14±Tol	XA±Tol	Recommended Bolt size	Ordering no.
32	32	7 H14	32	8	4	46	5.8	142 ^{+1.25}	3 ^{±1.5}	144 ^{+1.25}	M6	ML1032
40	36	9 H13	36	10	4	52	7.8	161 ^{+1.25}	3 ^{±1.5}	163 ^{+1.25}	M8	ML040
50	45	9 H13	45	12	5	65	7.8	170 ^{+1.25}	6 ^{±1.5}	175 ^{+1.25}	M8	ML050
63	50	9 H13	50	12	5	75	7.8	185 ^{±1.5}	6 ^{±2}	190 ^{±1.5}	M8	ML063
80	63	12 H14	63	17	6	95	9.8	210 ^{±1.5}	6 ^{±2}	215 ^{±1.5}	M10	ML1080
100	75	14.5 H14	71	19	6	115	11.8	220 ^{±1.5}	11 ^{±2}	230 ^{±1.5}	M12	ML1100

* Suitable for reaming

Flange

++ Add stroke twice

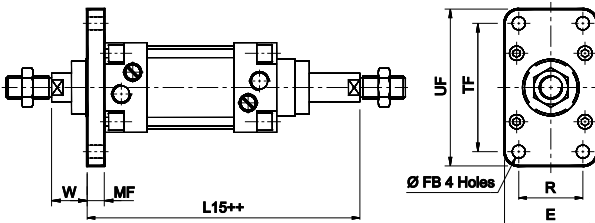

Cylinder bore Ø	TF ±0.3	R ±0.3	FB H13	MF	UF max	E max	W	Tol	L15	Tol	Recommended Bolt size	Ordering no.
32	64	32	7	10	80	50	16		131		M6	MF1032
40	72	36	9	10	90	55	20	±1.5	146	±1.5	M8	MF040
50	90	45	9	12	110	65	25		156		M8	MF050
63	100	50	9	12	125	83	25		171		M8	MF063
80	126	63	12	16	155	100	30	±1.8	191	±2	M10	MF1080
100	150	75	14	16	185	120	35		206		M12	MF1100

Female clevis

+ Add stroke

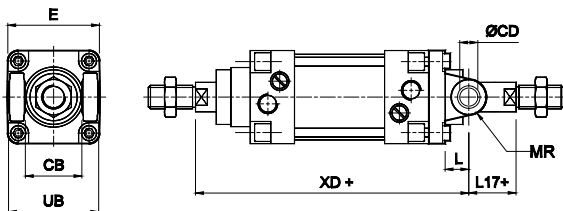

Cylinder bore Ø	CD H9	CB H14	L min	MR max	UB h14	E max	L17	Tol	XD	Tol	Ordering no.
32	10	26	12	11	45	45	5		142		MB032
40	12	28	15	13	52	54	6	±1.5	160	±1.25	MB040
50	12	32	15	13	60	64	11		170		MB050
63	16	40	20	17	70	82	6	±2	190		MB063
80	16	50	20	17	90	94	11	±1.8	210	±1.5	MB1080
100	20	60	25	21	110	111	11		230		MB1100

Trunnion

++ Add stroke twice

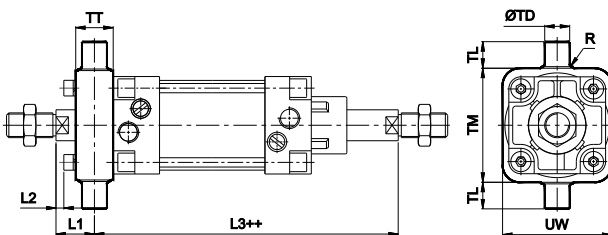

Cylinder bore Ø	TD e9	TL h14	TM h14	UW	TT	R	L1	Tol	L2 Approx	L3	Tol	Ordering no.
32	12	12	50	48	16	1	18		2	129		MT0032
40	16	16	63	55	22	1.5	19	±1.5	0	147		MT0040
50	16	16	75	70	24	1.6	25		5	156	±2	MT0050
63	20	20	90	86	28	1.6	23		-1	173		MT0063
80	20	20	110	110	32	1.6	30	±2	1.8	191		MT0080
100	25	25	132	135	40	2	31		-1.2	210		MT0100

Centre trunnion

+ Add stroke

++ Add stroke twice

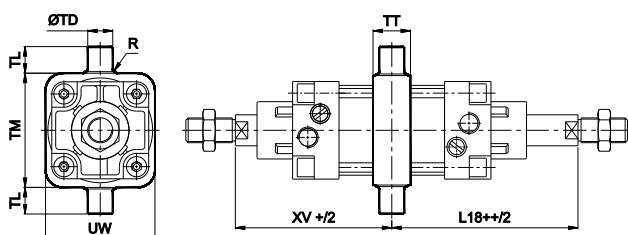

Cylinder bore Ø	TD e9	TL h14	TM h14	UW	TT	R	XV	Tol	L18	Tol
32	12	12	50	48	16	1	73		74	
40	16	16	63	55	22	1.5	82.5		83.5	
50	16	16	75	70	24	1.6	90	±2	91	±2
63	20	20	90	86	28	1.6	97.5		98.5	
80	20	20	110	110	32	1.6	110		111	
100	25	25	132	135	40	2	120		121	

Note : Cylinder with centre trunnion is factory fitted, please contact JANATICS - H.O

AIR CYLINDER

Series A10, A11

Cat No A10, A11 - 01 - 03

Accessories for Air Cylinder series A10, A11

Trunnion bracket

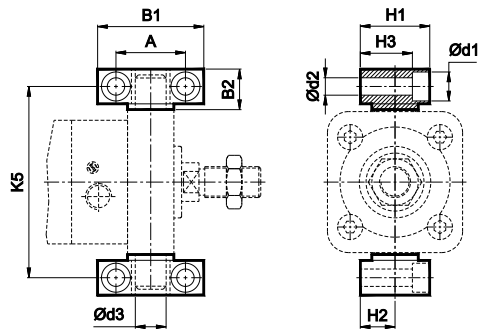

Cylinder bore Ø	B1	B2	A	d1	d2 H13	d3 H9	H1	H2	H3	K5 Js14	Ordering no.
32	46	18	32 ±0.2	11	6.6	12	30	15 ±0.1	23	71	AT032
40	55	21	36 ±0.2	15	9	16	36	18 ±0.1	27	87	AT040
50	55	21	36 ±0.2	15	9	16	36	18 ±0.1	27	99	AT040
63	65	23	42 ±0.2	16.5	11	20	40	20 ±0.1	29	116	AT063
80	65	23	42 ±0.2	16.5	11	20	40	20 ±0.1	29	136	AT063
100	75	28.5	50 ±0.2	20	14	25	50	25 ±0.1	37	164	AT100

Rod end Fork (ISO 8140)

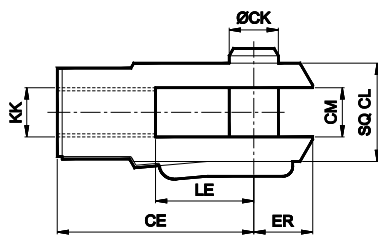

Cylinder bore Ø	KK	CE	CK f 8	CM B12	LE	ER max.	CL	Ordering no.
32	M10 x 1.25	40	10	10	20	16	20	AF010
40	M12 x 1.25	48	12	12	24	19	24	AF012
50 / 63	M16 x 1.5	64	16	16	32	25	32	AF016
80 / 100	M20 x 1.5	80	20	20	40	32	40	AF020

Rod end Aligner

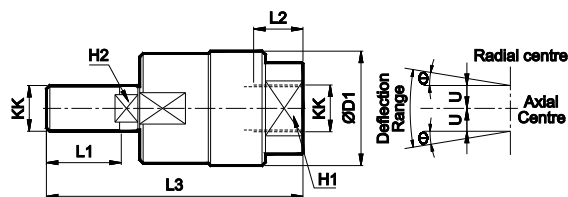

Cylinder bore Ø	KK	L1	L2	L3	H1	H2	D1	U	± θ°	Ordering no.
32	M10 x 1.25	20	14	65	17	8	28	0.75	5	AR010
40	M12 x 1.25	22	18	75	19	10	32	1	5	AR012
50 / 63	M16 x 1.5	25	22	91	27	13	41	1	5	AR016
80 / 100	M20 x 1.5	30	28	112	32	16	50	1.5	5	AR020

Rod end spherical eye (ISO 8139)

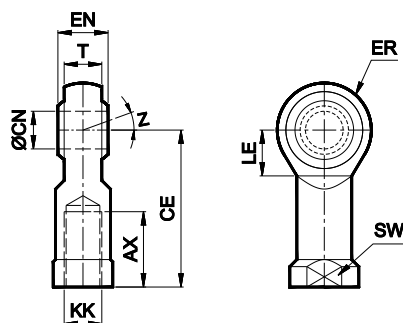

Cylinder bore Ø	KK	CN H9	T	EN h12	CE	LE min	ER max	AX	SW	Z	Ordering no.
32	M10 x 1.25	10	10.5	14	43	15	14	20	17	13°	AP010
40	M12 x 1.25	12	12	16	50	17	16	22	19		AP012
50 / 63	M16 x 1.5	16	15	21	64	22	21	28	22	15°	AP016
80 / 100	M20 x 1.5	20	18	25	77	26	25	33	30/32		AP020

AIR CYLINDER

Series A10, A11

Cat No A10, A11 - 01 - 03

How to order

Model		Cylinder bore (mm)		Stroke (mm)		Mountings	
10	Magnetic cylinder	032	- Ø 32	025	- 25	O	- Basic
11	Standard cylinder	040	- Ø 40	050	- 50	L	- Foot Mounting
		050	- Ø 50	080	- 80	F	- Flange
		063	- Ø 63	100	- 100	B	- Female Clevis
		080	- Ø 80	125	- 125	N	- Trunnion
		100	- Ø 100	160	- 160	T	- Center Trunnion
				200	- 200		
				250	- 250		
				300	- 300		
				320	- 320		
				400	- 400		
				500	- 500		

Note

For details of Accessories for Magnetic sensor, refer catalogue **Cat No A12, A13 - 01 - 02** (Page no. 1.1.6)

Example:

Ordering no. for magnetic cylinder with 40 dia bore, 50 mm stroke with female clevis mounting: **A10 040 050 B**





Note:

If ordered as 40 dia, 50 mm stroke cylinder, Basic cylinder **A11 040 050 O** will be supplied.

For repeat order when the details are taken from cylinder nameplate, mention the mounting style separately.

For ordering **Accessories** refer corresponding tables for part numbers.

For ordering individual **Mounting** kits (If needed separately) the order numbers are as below

Cylinder bore Ø	Foot mounting *	Flange *	Female clevis *	Trunnion *
				
32	ML1032	MF1032	MB032	MT0032
40	ML040	MF040	MB040	MT0040
50	ML050	MF050	MB050	MT0050
63	ML063	MF063	MB063	MT0063
80	ML1080	MF1080	MB1080	MT0080
100	ML1100	MF1100	MB1100	MT0100

* Supplied with 4nos. of screws

For your special requirements of cylinders or for further informations contact your regional dealer or **JANATICS**

Subject to change