



# AIR PREPARATION UNITS

## LUBRICATOR Series L1

Cat No L1 - 01 - C

### LUBRICATOR - 1/4, 3/8, 1/2, 3/4, 1"

#### Features

- Conforms to ISO 6301 - 1
- Suitable for Modular mounting
- Fog / Mist type
- Fine adjustment of lubrication
- Steel bowl guard, bayonet type on L14, L15 & L17 models and threaded type on L13 mode
- Lubrication proportional to flow



#### Technical Specifications

Model	L13	L14	L15	L17	L17
Medium	Compressed air - Filtered				
Port size	G1/4	G3/8	G1/2	G3/4	G1
Flow rate (lts / min) <sup>@</sup>	1350	3000	5650	7200	9000
Maximum supply pressure (bar)	10				
Ambient / Medium temperature	5° - 50° C				
Min operating flow (lts / min)	12	40	45	50	50
Bowl capacity (ml) (at maximum oil level)	20	57	152	200	200
Recommended oil	ISO VG 32 (Servo System 32)				
Bowl material	Polycarbonate				
Installation	Vertical (as in the picture)				
Materials of construction	Aluminium, Bronze, Steel, Acetal, Polycarbonate, SS, Nitrile				
Optional accessories *	Clamp, Modular mounting kit				
Weight (Kg)	0.19	0.30	0.56	1.3	1.2

<sup>@</sup> Supply pressure 6 bar , pressure drop  $\Delta p = 0.5$  bar ( For standard models )

\* For details refer optional accessories Cat No APA - 01 - C

#### Precautions

1. Note the direction of flow before installation and connect piping accordingly.
2. Flush pipings for dirt, dust, rust and other foreign particles.
3. Install in clean atmosphere.
4. Nipples of taper threads ( R ) to be used with teflon tape. Ensure teflon tape does not enter the unit during tightening. Nipples of straight threads ( G ) to be used with sealing washer.
5. Polycarbonate bowls may get damaged and possibly fail if exposed to synthetic oils, thinner, solvents, trichloroethylene, kerosene or other aromatic hydrocarbons.
6. Oil may be filled when under pressure. However it is recommended to vent the air completely before filling the oil.

# AIR PREPARATION UNITS

## LUBRICATOR Series L1

Cat No L1 - 01 - C

Model L13

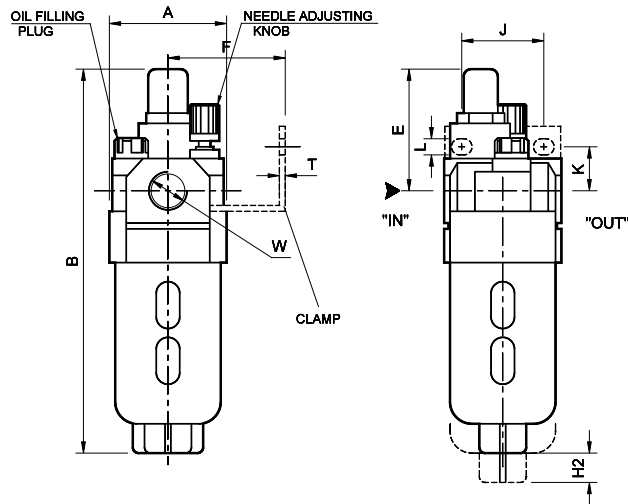

Model L14 & L15

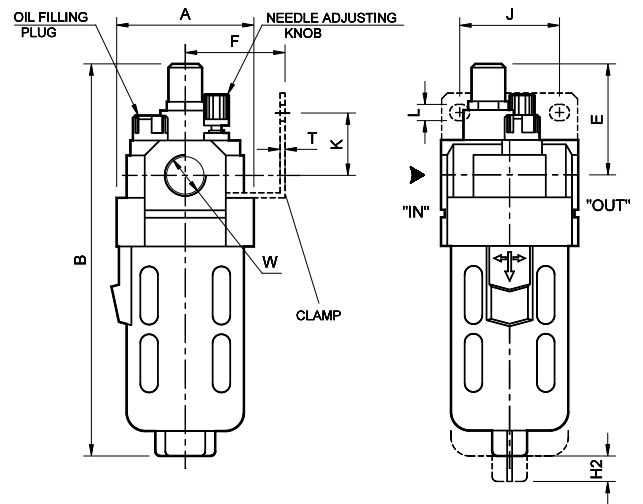

Model L17

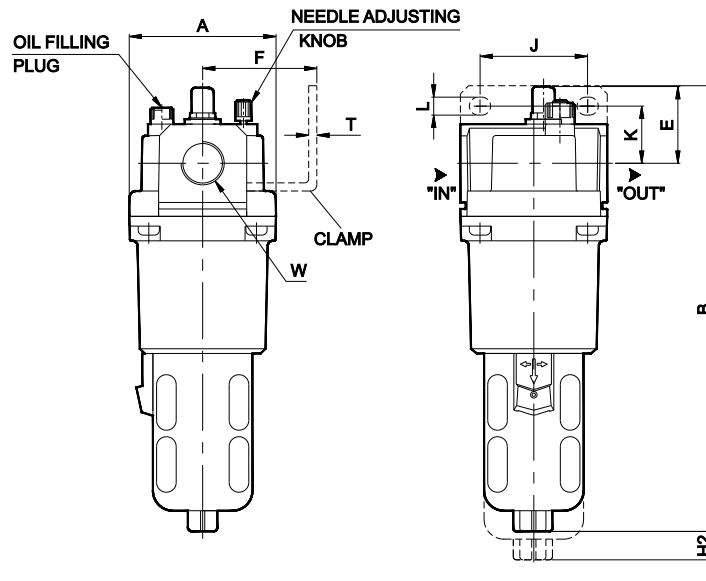

Model	W	A	B	E	K	F	J	L	T	H2
L13	G1/4	SQ 40	135	42	15	30	28	5.5	2	35
L14	G3/8	SQ 55	157	44	25	40	40	6.5	2	45
L15	G1/2	SQ 70	190	46	25	50	55	8.5	2	45
L17	G3/4	SQ 90	273	47	35	70	66	11	5	45
L17	G1	SQ 90	273	47	35	70	66	11	5	45

For Details of Clamp see optional accessories Cat No APA - 01 - C

# AIR PREPARATION UNITS

## LUBRICATOR Series L1

Cat No L1 - 01 - C

### Flow Graphs

1/4" LUBRICATOR

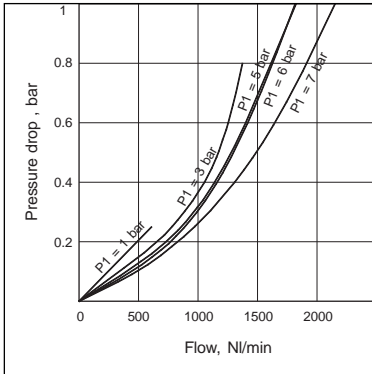

3/8" LUBRICATOR

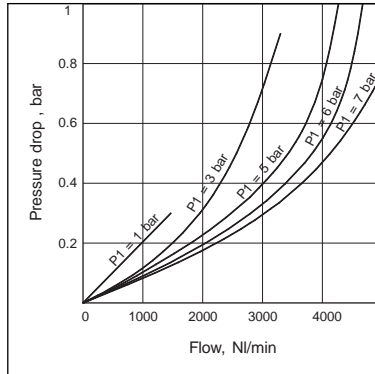

1/2" LUBRICATOR

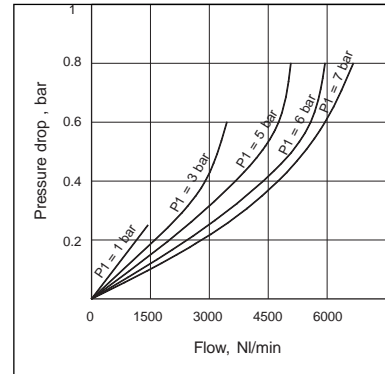

3/4" LUBRICATOR

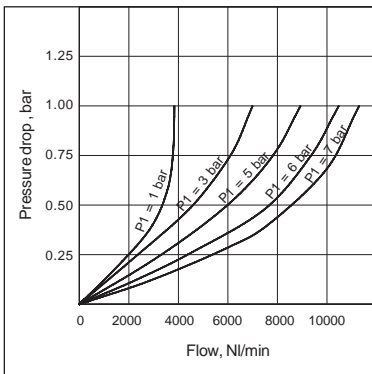

1" LUBRICATOR

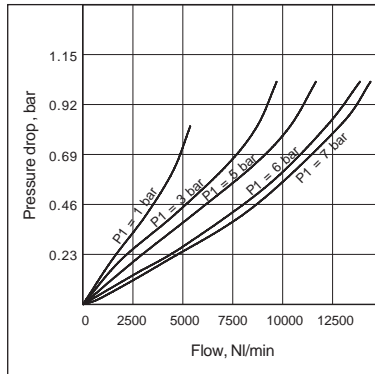

### How to order

**L1**

Body & Port size	
361	G1/4
462	G3/8
563	G1/2
764	G3/4
765	G1

### Principle of Operation

A part of the air entering the Lubricator through " IN " pressurises the bowl chamber.

Flow of full air goes through " OUT " deflecting the " Deflector " and creating pressure drop below the sight dome.

The pressure in the Bowl presses the oil through the suction tube and the oil flows through the sight dome. All the oil drops seen through the sight dome mixes with the main - stream air and comes through " OUT ". The required oil drops can be adjusted by the adjusting needle.

Ordering example : Lubricator - 3/8 port size ( with G3/8 port ) : Ordering No: L1462